

Instruction manual

Slit lamp bon SL-72/SL-75



GA bon SL-72_75 Rev 1.1 E 180506

PO Box 32 26
23581 Lübeck

Phone 0451/ 80 900-0
Fax 0451/ 80 900-10

Stellmacherstraße 14
23556 Lübeck

E-Mail: call@bon.de
Internet: www.bon.de

Sparkasse zu Lübeck
(Sort code 230 501 01) Acc.No. 1 014 885

Swift / BIC: HSHN DE H1 SPL
IBAN: DE 2305 0101 0001 0148 85

Commerzbank Lübeck
(Sort code 230 400 22) Acc.No. 0 107 755

Postbank Hamburg
(Sort code 200 100 20) Acc.No. 409 22-204

1	Introduction	4
2	Important information	5
	2.1 System information.....	5
	2.2 Application and classification	5
	2.3 Liability	5
	2.4 Scope of delivery.....	6
3	Safety instructions	7
4	Description of the device.....	8
	4.1 Composition of the slit lamp	8
	4.2 Microscope	9
	4.3 Slit projector	10
5	Setting-up, assembly and repair	11
6	Powering-up	13
7	Operation of the apparatus	14
	7.1 Focussing the microscope.....	14
	7.2 Examination.....	14
8	Maintenance and care.....	15
	8.1 Care.....	15
	8.2 Maintenance.....	15
	8.3 Repairs you can carry out yourself	16
	8.3.1 Changing the slit projector lamps	16
	8.3.2 Changing the focussing light lamp.....	16
	8.3.3 Changing the fuses	17
	8.4 Power supply disruptions	17
9	Guarantee	18
10	Technical data	19

Appendix: EC Declaration of Conformity

1 Introduction

Dear customer

Thank you for purchasing our bon SL-72/SL-75 slit lamp. Please read the operating instructions carefully before using the device. Keep this instruction manual safe for further use.

Please observe the safety instructions.

If you have any further questions, please contact our customer helpline.

Meaning of the symbols in the operating instructions



Caution! Please observe the safety instructions with this symbol to prevent personal danger or damage to property.



Important! Indicates particularly important information to maintain the function of the device/system or to extend its life.



Note! Indicates information for correct use so that errors may be avoided.

This publication may not be copied or transferred without prior agreement from bon Optic. bon Optic reserves the right to make changes in the interest of technical development. These operating instructions are not subject to updating.

2 Important information

2.1 System information

Manufacturer: bon Optic Vertriebsgesellschaft mbH · Stellmacherstr. 14 · D- 23556 Lübeck

Name of device : bon SL-72/SL-75

2.2 Application and classification

The bon SL-72/SL-75 slit lamp is used to examine the structures at the front of the eye. The SL-72/SL-75 slit lamp is a Class 1 non-invasive, active medical device in accordance with the classification regulations of Directive 93/42/EWG on medical devices (MDD).

2.3 Liability

The slit lamp is manufactured according to the current technical status and the recognised safety regulations and is tested in accordance with strict quality criteria.

bon Optic only accepts liability for the safety, reliability and performance of the slit lamp if

- assembly and any changes or repairs have been carried out by a person authorised by bon Optic to do so.
- the power supply to which the device is connected corresponds to the national legislation.
- the device is operated in accordance with these operating instructions.
- the operator complies with the Ordinance on the Operation of Medical Devices.

If the device is assembled, changed or repaired by an unauthorised person, if it is improperly maintained or not used as described in 2.2, the manufacturer is no longer liable.

2.4 Scope of delivery

- 1 x slit lamp bon SL-72/SL-75
- 1 x instruction manual
- 1 x dust shield
- 1 x focussing light
- 1 x replacement lamp 6V/20W
- 1 x non-slip surface
- 1 x mouth cover with fixing screw
- 1 x test rod
- 2 x gear wheel plates
- 2 x running wheel covers
- 1 x set of screws
- 1 x power socket with front cover

Components needed for operation

- Head rest
- Mains adaptor

Special equipment

- Eyepiece for length and angle measurements
- Applanation tonometer
- InLine video package, photo attachment
- Digital image processing (Eye Image)

3 Safety instructions

Please follow the legal requirements on accident prevention and observe the following safety instructions!

Setting-up and assembly:

- The slit lamp should not be assembled and operated in damp rooms.
- Ensure that the device is on a level and stable surface during assembly.
- The mains voltage must be the same as stated on the product label.

Operating:

- Do not subject the slit lamp to extremes of temperature. It is recommended that the device be used at temperatures of between +10° C and +40° C.
- The slit lamp must not be used in areas where there is a danger of explosion.
- Avoid dropping or splashing water on the device.
- The slit lamp must only be used by authorised persons.
- Do not attempt to move or shake the slit lamp with excessive force. First check whether the adjustment screws have been loosened.
- The moveable arm and slit projector can move up and down between their bases. Make sure you don't squash your hands!
- Do not open the protective cover of the halogen lamp whilst the device is in use. You could be burnt!

Other information:

- Do not pull on the power cable in order to remove the plug from the socket. Pull on the plug directly.
- Ensure that no damage occurs to the cable (e.g. sharp edges, high heat).

4 Description of the device

The bon slit lamp SL-72/SL-75 is a professional universal instrument with magnification adjustment for examination of the front structures of the eye.

4.1 Composition of the slit lamp

Main components:

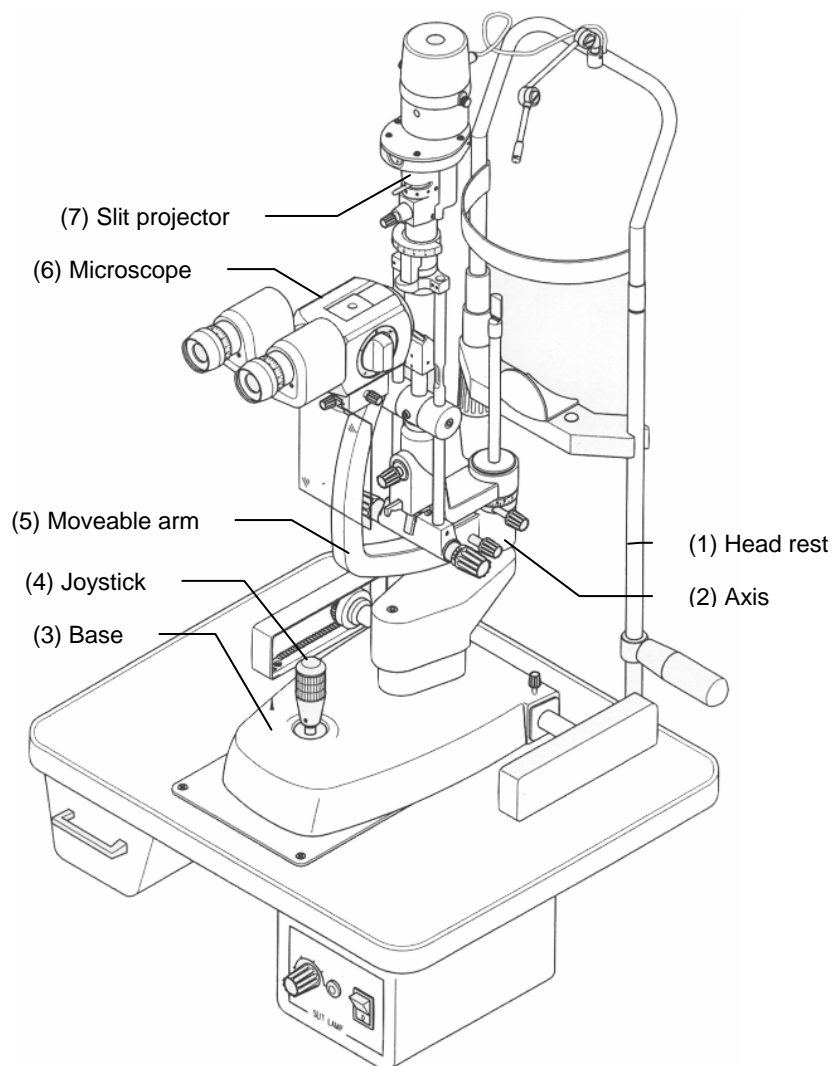

Diagram 4-1: Slit lamp bon SL-72/SL-75

The slit lamp sits on a base (3) with orthogonal movement. The slit lamp can be moved in an x and y direction using the joystick (4). Moving the joystick from left to right will change the height (approx. 4cm) of both the microscope (6) and the slit projector (7) to line up with the eye to be examined. The microscope and slit projector can be moved independently on the joint axis (2).

4.2 Microscope

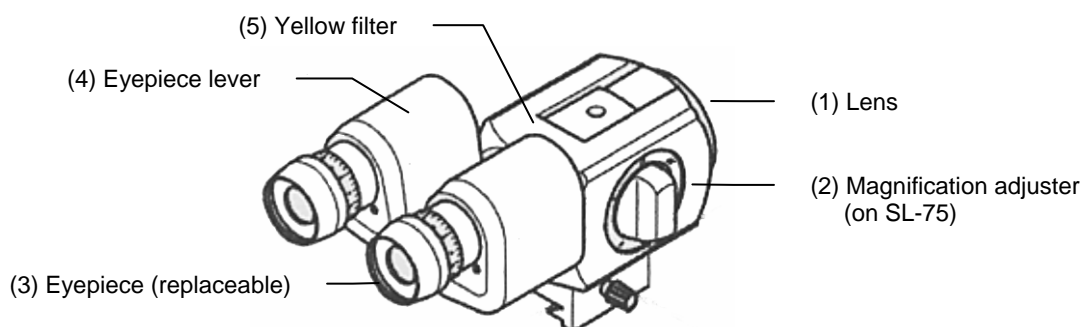

Diagram 4-2: Microscope of the SL-72/SL-75

The eyepiece (3) with standard 12.5x magnification enables an ametropia equalisation of ± 5 dpt. By extending or pushing in the eyepiece lever (4), the distance to the pupil can be adjusted.

Magnification adjuster (2): 6x/10x/16x/25x/40x
for SL-72: 10x/16x (using a switch)

The slit lamp SL-72/SL-75 enables:

- Microscopy of the back structures of the eye using a Goldmann contact glass.
- Examination of the eye and evaluation of the position of contact lenses with fluorescent light.
- Tonometry with a Goldmann tonometer.
- Measurement of the cornea and contact lenses with a length measurement eyepiece.

4.3 Slit projector

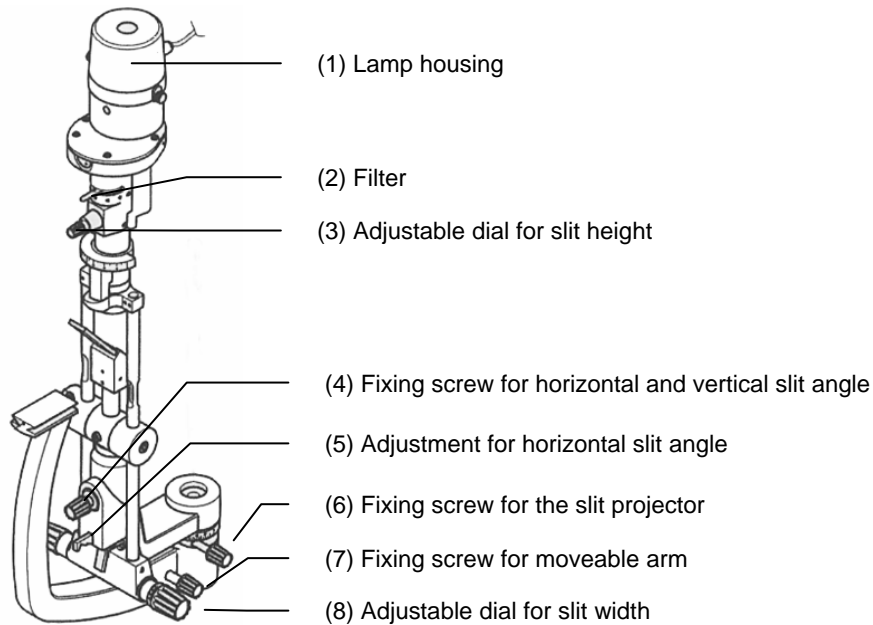

Diagram 4-3: Slit projector

The slit projector offers a wide spectrum of different types of lighting. The slit width (8) can be continuously adjusted from 0 to 14mm. The slit height (3) can be continuously varied from 1.8 to 12mm with the optional use of apertures and a blue filter. Green, blue, red and grey (heat protection) filters are also available as filters (2).

By loosening the fixing screw (4), the slit projector can be inclined horizontally at four different levels (5) and turned vertically.

5 Setting-up, assembly and repair

- a) Screw the gearwheel plates onto the table base with two recessed-head screws each. Ensure that the sides of the gear wheels face outwards!
- b) Screw the Teflon non-slip surface to the table base with four recessed-head screws.
- c) Remove a gearwheel from the guiding rod and push it through the base. Then screw the gear wheel back in.
- d) Place the base on the table in such a way that the joystick is situated over the non-slip surface and the gearwheels sit on the gearwheel plate.
- e) Place one protective cover to the side of the assembled gearwheel plate and then push the base forward as far as it will go.
- f) Check that the facing gearwheel is also on the last pinion. This is the only way of ensuring that the two gear wheels run parallel.
- g) Place the second protective cover on the gearwheel plate.

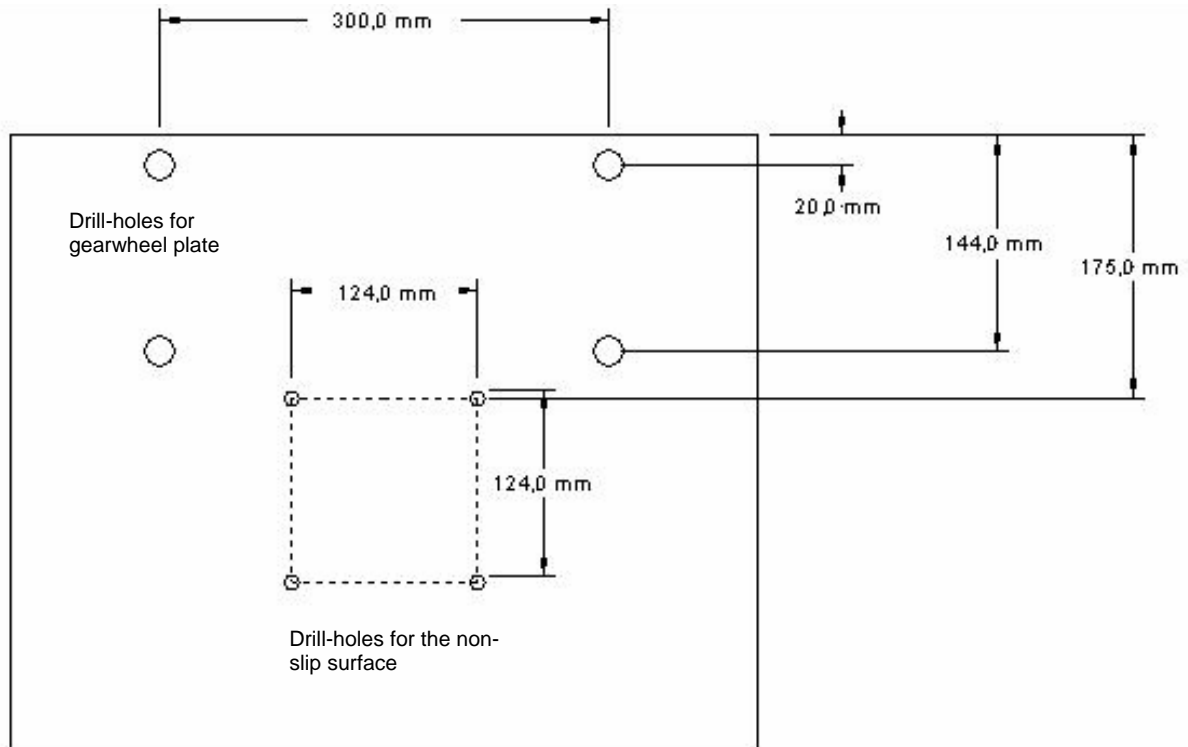

Diagram 5-1: Measurements for drill-holes

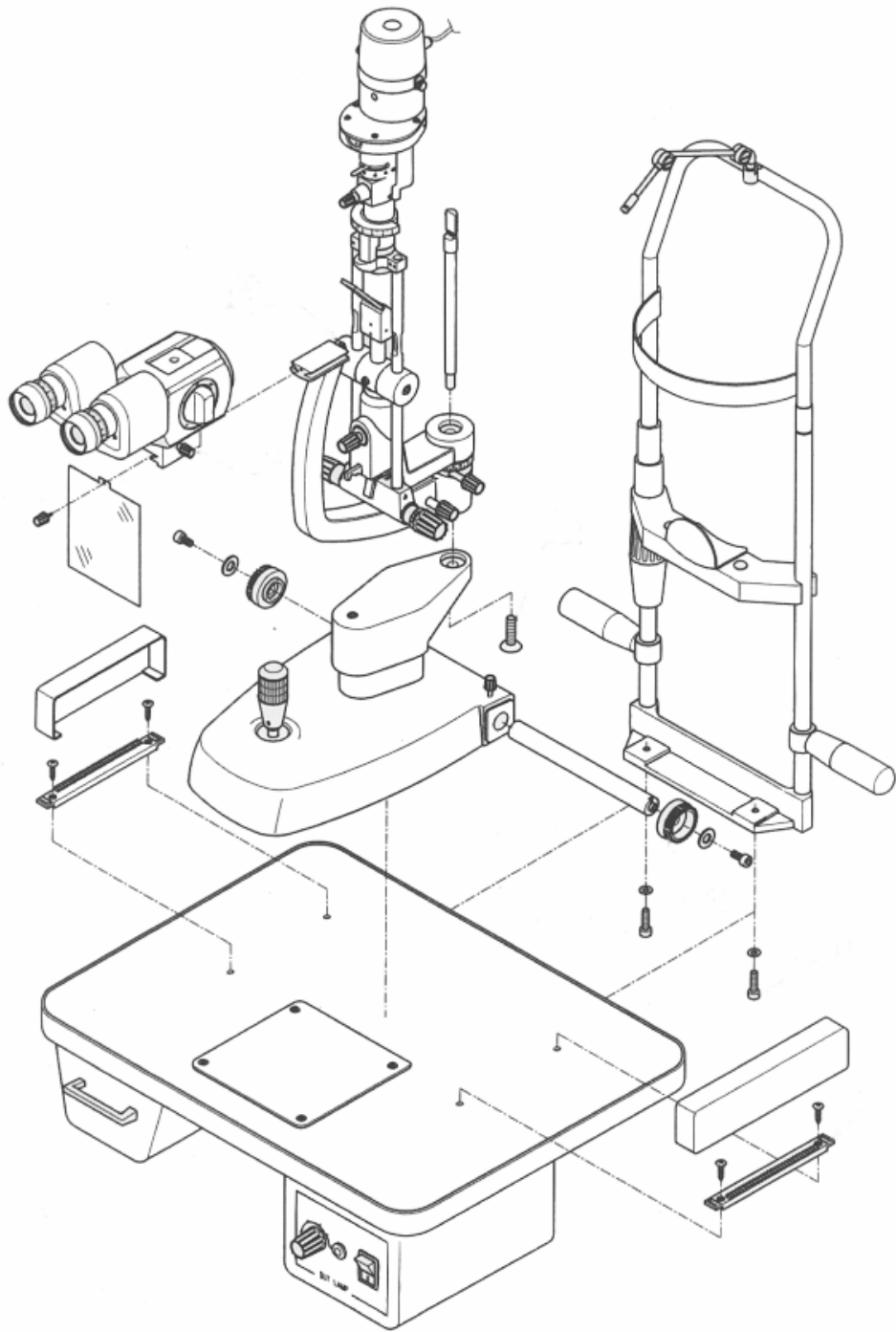

Diagram 5-2: Assembly sketch SL-72/SL-75

6 Powering-up

The slit lamp can be supplied with electricity by a separate mains adaptor or via an examination unit.

a) Original mains adaptor:

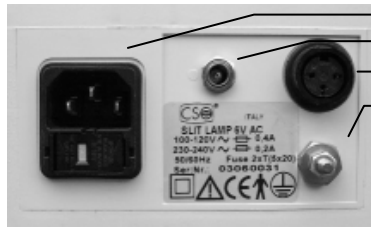

Diagram 6-1: mains connection - back

- (1) Mains connection and fuse
- (2) Focussing light connection
- (3) Slit lamp connection
- (4) Protective earth connection

- (5) Dimmer switch
- (6) Problem indicator
- (7) Power switch



Diagram 6-2: mains connection - front

1. Plug the slit lamp into connection (3).
2. Plug the focussing light into connection (2) (optional).
3. Earth the slit lamp to connection (4).
4. Plug the mains adaptor (1) into the mains socket using the power cable.
5. Press the on/off switch (7).

The slit lamp is now ready for use. You can change the brightness of the lamp in the slit lamp using the dimmer switch (5).

b) Electricity via an examination unit

Only an expert must install the slit lamp to an examination unit. In particular, please ensure that the supply voltage and power meet the requirements (see chapter on Technical data). Use the appropriate operating controls on your examination unit to power the slit lamp.

7 Operation of the apparatus

7.1 Focussing the microscope



Remove the cap and place the test rod in the holder as shown. Turn the slit lamp on.

Focus the eyepiece so that the grainy surface of the test rod can be seen in focus at medium magnification.

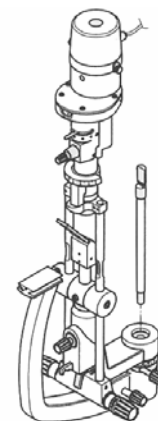

Diagram 7-1: Slit projector

7.2 Examination

- Allow the patient to rest his/her chin comfortably on the chin rest and ensure that his/her forehead is on the forehead rest.
- Use the height adjuster on the head rest to bring the eyes of the patient up to the level of the making of the head rest (line of vision height).
- Turn the slit lamp on.
- Look through the microscope and set the desired magnification level.
- Centre and focus the eye to be examined with the control level on the base.
- In order to reduce patients' discomfort, the brightness can be adjusted using the mains adaptor.

When directly lighting the eye, the slit of the slit projector is to be projected in line with the viewing level of the microscope. The height and width of the slit can be adjusted on the slit projector (see diag. 4.3, page 9). With the slit made smaller, the ray of light from the slit lights a small section of the eye, placing it into high contrast. When widened, the section of the eye that can be examined is larger, but the contrast is not so high.

For examination in a red-free image, a green filter is available. Turn the filter dial to the position with the green markings. The blue filter aids observation of intraocular pressure measurements, e.g. with an Applanation tonometer. The filter with the orange markings can be used to protect the patient's eye from heat. The yellow filter on the microscope (see diag. 4.2, page 8) can be used in conjunction with the blue filter for fluorescence observation, e.g. to view the position of contact lenses. Use the grey filter to dim the light.

8 Maintenance and care

8.1 Care



Clean the chin rest and the forehead rest on the head rest with a clean damp cloth. Do not use any abrasive or harsh cleaning products! If the lens or eyepiece becomes dirty, please use a soft brush or a lens cleaning cloth.

Do not use disinfection alcohol!

8.2 Maintenance

When used properly, the slit lamp should not require repeated maintenance. For repairs or technical problems please contact the bon Optic customer services department.

8.3 Repairs you can carry out yourself

8.3.1 Changing the slit projector lamps



Important

The type of lamp used can vary depending on the version of the product. Please check which type of lamp is used in your slit lamp:

- a) 6V/20W PG 22 – 6.35 (Standard)
- b) 12V/20W PG 22 – 6.35

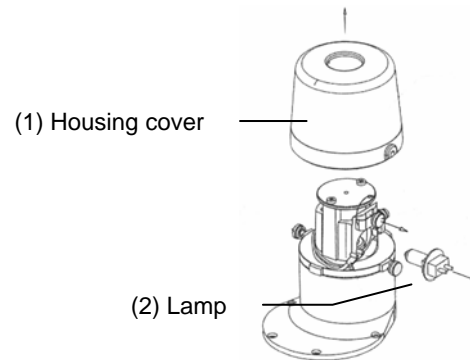

Diagram 8-1: Slit projector lamp housing



- 1) Disconnect the slit lamp from the power supply.
- 2) To avoid burning yourself, leave the lamp to cool for several minutes before changing it.
- 3) Loosen the screw on the housing cover (1) and remove it in an upwards direction.
- 4) Loosen the holding piece on the lamp (2) and then remove the lamp from the holder.
- 5) Place the new lamp in the holder. Do not touch the glass body of the lamp with your fingers (to avoid dirtying the lamp!).
- 6) Fix the holding piece into position and screw the housing cover back on.
- 7) Check that it works by turning the slit lamp on.

8.3.2 Changing the focussing light lamp

Lamp used: 12 V, 60 mA



- 1) Disconnect the focussing lamp from the power supply.
- 2) Unscrew the red cap from the focussing light and remove the old lamp.
- 3) Insert the new lamp and screw the red cap back on.

8.3.3 Changing the fuses

Only for original mains adaptor!



Use only fuses with the same fuse values as those shown on the main adaptor!

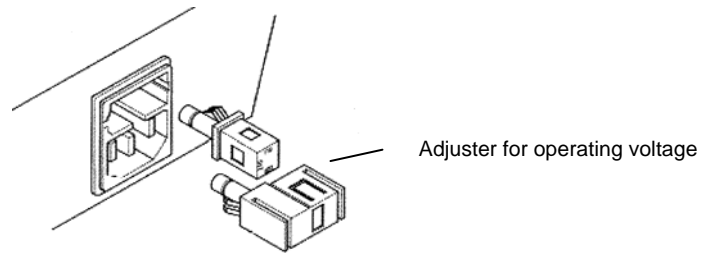

Diagram 8-2: Mains adaptor (back)



- 1) Disconnect from the mains before changing the fuse!
- 2) Open the required fuse element.
- 3) Remove the old fuse from the holder and replace it with a new fuse of the same type.
- 4) Place the fuse holder back in the fuse socket.
- 5) Close the fuse element.

8.4 Power supply disruptions

Should EMC disruptions (electro-magnetic compatibility) occur from the mains adaptor, please contact bon Optic customer support.

9 Guarantee

Should defects as the result of material or production errors occur within 24 months of purchase, we guarantee free-of-charge repair of the slit lamp or we will decide whether to offer you a free exchange, provided that:

- A receipt with the date of purchase can be provided.
- The device has been used properly and in accordance with the conditions of use.
- Repairs have not been carried out by anyone other than the bon Optic customer service team or persons authorised by bon Optic.

Guarantee services do not result in extension of the guarantee, nor do they represent the start of a new guarantee. The sales guarantee is not applicable to consumable products.

The terms and conditions of trade of bon Optic also apply.

10 Technical data

Slit lamp:

Classification (EN 60601-1):	II, Type B
Slit lamp measurements (H/W):	700x380 mm
Weight:	9.5 kg (excl. mains adaptor)
Slit projector halogen lamp:	6V/20W PG 22 (Standard)
Focussing light lamp:	12V/60mA
Slit length (continuous):	1.8 - 12 mm
Slit width (continuous):	0 - 14 mm
Vertical incline angle of slit:	(0/5/10/15/20) °
Smallest point:	0.3 mm
Maximum slit length:	14 mm
Measurements of the light field:	(0.2/1/3//5/9/12) mm
Filter:	blue, green, yellow, grey, heat protection
Rotation of the slit:	+/- 90°
Movement of the slit lamp to/from the microscope:	+/- 90°
Magnification SL-72:	10x/16x
Magnification SL-75:	6x/10x/16x/25x/40x
Ametropia equalisation:	+/- 5 dpt.

Base (x,y,z):

Sideways adjustment (left/right):	108 mm (x)
Lengthways adjustment (forwards/backwards):	113 mm (y)
Height adjustment:	approx. 40 mm (z)





Mains adaptor:



Input supply voltage:	100-120V AC / 230-240V AC
Output voltage:	6V AC (Slit lamp), 12V AC (Focussing lamp)
Power frequency:	50/60 Hz
Connection power:	40VA
Fuses:	2 x 0.4A T (100-120V) / 2 x 0.2A T (230-240V)
Safety class:	II
Safety type:	IP 21
Device type:	B



Disposal of old Electrical & Electronic Equipment (Applicable throughout the European Union and other European countries with separate collection programs)

This symbol, found on your product or on its packaging, indicates that this product should not be treated as household waste when you wish to dispose of it. Instead, it should be handed over to an applicable collection point for the recycling of electrical and electronic equipment. If you have any further questions, please contact bon optic.

Label symbols	
	Protective earth
	Safety class II (isolated)
	Fuse
	Read instruction manual
	Application type B

Transport requirements	
	Temperature: -5 °C to +45 °C (+23 °F to +113 °F)
	Air pressure: 650 hPa to 1100 hPa
	Relative humidity: 25% to 80%
Maximum conditions – no longer than 60 days in a row	

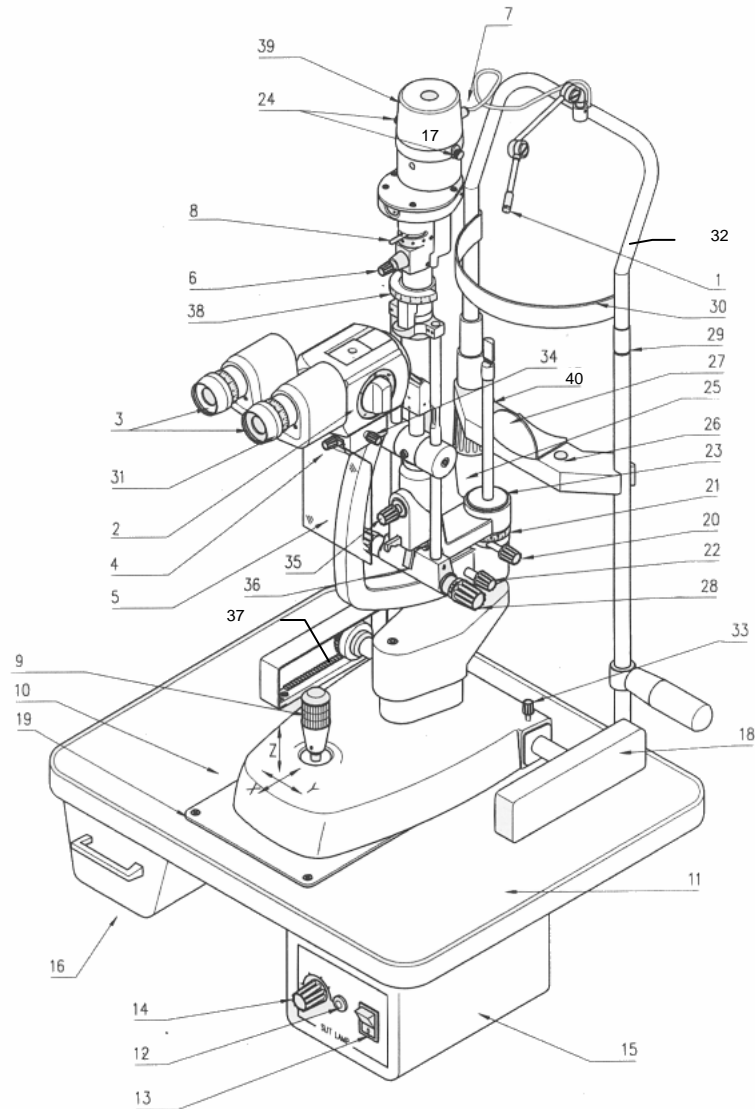

Diagram 10-1: Slit lamp components

- | | |
|-----------------------------------|-------------------------------|
| 1) Focussing light | 21) Scale for slit projector |
| 2) Eyepiece lever | 22) Screw for moveable arm |
| 3) Eyepiece (replaceable) | 23) Holder for test rod |
| 4) Screw for mouth cover | 24) Screw-top lamp housing |
| 5) Mouth cover | 25) Head rest height adjuster |
| 6) Dial for slit length | 26) Chin paper fixing point |
| 7) Lamp connection | 27) Chin rest |
| 8) Filter dial | 28) Slit width dial |
| 9) Joystick | 29) Eye level markings |
| 10) Base with orthogonal movement | 30) Forehead rest |
| 11) Table plate | 31) Microscope |
| 12) Warning Light | 32) Head rest |
| 13) Power switch | 33) Screw for base |
| 14) Dimmer switch | 34) Screw for microscope |
| 15) Mains adaptor (transformer) | 35) Screw for slit projector |
| 16) Drawer | 36) Lock |
| 17) Lamp (not visible) | 37) Gear wheel rod |
| 18) Running wheel cover | 38) Scale |
| 19) Teflon non-slip surface | 39) Lamp housing |
| 20) Screw for slit projector | 40) Test rod |

EU - KONFORMITÄTSERKLÄRUNG

EC – DECLARATION OF CONFORMITY

Hersteller-Adresse:
(Manufacturer's address)

bon
Optic Vertriebsgesellschaft mbH
Stellmacherstraße 14
D-23556 Lübeck

Gerätetyp / UMDNS-CODE:
(Device type/ UMDNS-CODE)

Spaltlampe (12-281)
Slit lamp (12-281)

Gerätebezeichnung:
(Device name)

Spaltlampe SL-72/SL-75/SL-85/SL-E/SL-Zoom
Slit lamp SL-72/SL-75/SL-85/SL-E/SL-Zoom

Klassifizierung:
(Classification)

1 (Richtlinie 93/42/EWG, Anhang IX, Regel 1)
1 (MDD 93/42/EEC, appendix IX, rule 1)

Wir erklären hiermit die Übereinstimmung des vorgenannten Produkts mit der EU-Richtlinie 93/42/EWG über Medizinprodukte.

We declare the compliance of the device with the requirements of the Directive 93/42/EEC on medical devices.

Angewandete Normen:
(Applicable standards)

DIN EN 60601-1 (03/96)
DIN EN 60601-1-2 (09/94)
EN 1441 (10/97)

Überwachungsbehörde/ ID-Nr.:
(Notified body/ Identification number)

IMQ / 0051

Das Gerät ist gekennzeichnet mit / The device is marked with



Lübeck, 01 June 2004



(H. Jochen Kaber, Managing director)